

Lift-Assure

Plumbing Systems



Product Features:

- 3 Input Ports
- Unique Design
- Comfort and Stylishness

Models:

- LA-Round
- LA-Elongated
- LA-European Design

Please read all of the following instructions before beginning installation.

1. Check to make sure the toilet functions properly before making any construction changes to the property.
2. **Important:** Do not flush anything other than organic human waste and toilet tissue.
3. Do not allow the unit to freeze.
4. Make sure any pipes exposed to freezing temperatures are insulated.
5. Check plumbing fixtures attached to the pump for leaks.
6. Do not use during a power failure, the pump will not operate causing the unit to overflow.
7. Do **NOT** use one-way air admittance valves. Macerating pumps needs two-way air movement.
8. The pump must be connected to a properly grounded CFCI-ground fault circuit interrupted receptacle on a dedicated 15 AMP circuit.
9. Always disconnect the power source before servicing or handling the pump.
10. Do not use an extension cord with unit.
11. Refrain from making any modifications to, or remove the ground pin from, the pump's power supply cord plug.

Required Tools

- Pipe Saw
- Philips screw driver
- Flathead screw driver
- $\frac{5}{16}$ " Socket wrench
- Hammer
- Level
- Tape Measure
- Drill
- $\frac{1}{2}$ " Masonry Drill Bit (Concrete Floors)
- $\frac{1}{4}$ " Drill Bit (Wood Floors)

Recommended Materials

- PVC/ABS primer and cement
- 1 $\frac{1}{4}$ ", t- $\frac{1}{2}$ " rigid (Schedule 40) pipe fittings, as needed
- 3" pipe extension and 3" coupler (depends on installation)
- Tee-wye sewer connection
- Ball valves sized to inlet and discharge pipe sizes
- 2" sewage pump check valve (depending on installation)
- For optimal performance, use long sweep 90° angles.

Parts Included



1. Water Tank

2. Rear Discharge Toilet and Lid

Dual Button



Lever



Macerator Parts:

1. Attachment Fitting

2. Hose Clamps

3. Cover Plate

4. Screw Clamps

5. Discharge Pipe

6. 1 1/2" Threaded Plug
Cap & Seals



1

6

2

3

4

Macerator Specifications	
Power Supply/Frequency	120V/60Hz
Input Ports	3
Current/Wattage	800W
Circuit Requirement	Dedicated 15 AMP
Duty Cycle	38GPM, 22 ft., 295 ft., H Run 1 Plus HP Pump

Toilet Models Specifications			
<i>Toilet Models</i> ➡ <i>Specifications</i> ↓	LA-European Model Specifications	LA-Round Model Specifications	LA-Elongated Model Specifications
Toilet Material	Ceramic	Ceramic	Ceramic
Flush Type	Dual Button	Lever	Lever
Color	White	White	White
Toilet Depth	27 in.	24 in.	27 in.
Bowl Height	14 3/4 in.	14 7/8 in.	16 1/2 in.

Plumbing Layout For Your Consideration

Fig.1: Pumping Head

- 1) Outlet check valve is necessary
- 2) Install an extra manual check valve for repair (Suggestion)
- 3) Lift the shower 6 ½ inches high, when you connect the side inlet
- 4) Using filter in shower & lavatory to reduce hair come into machine

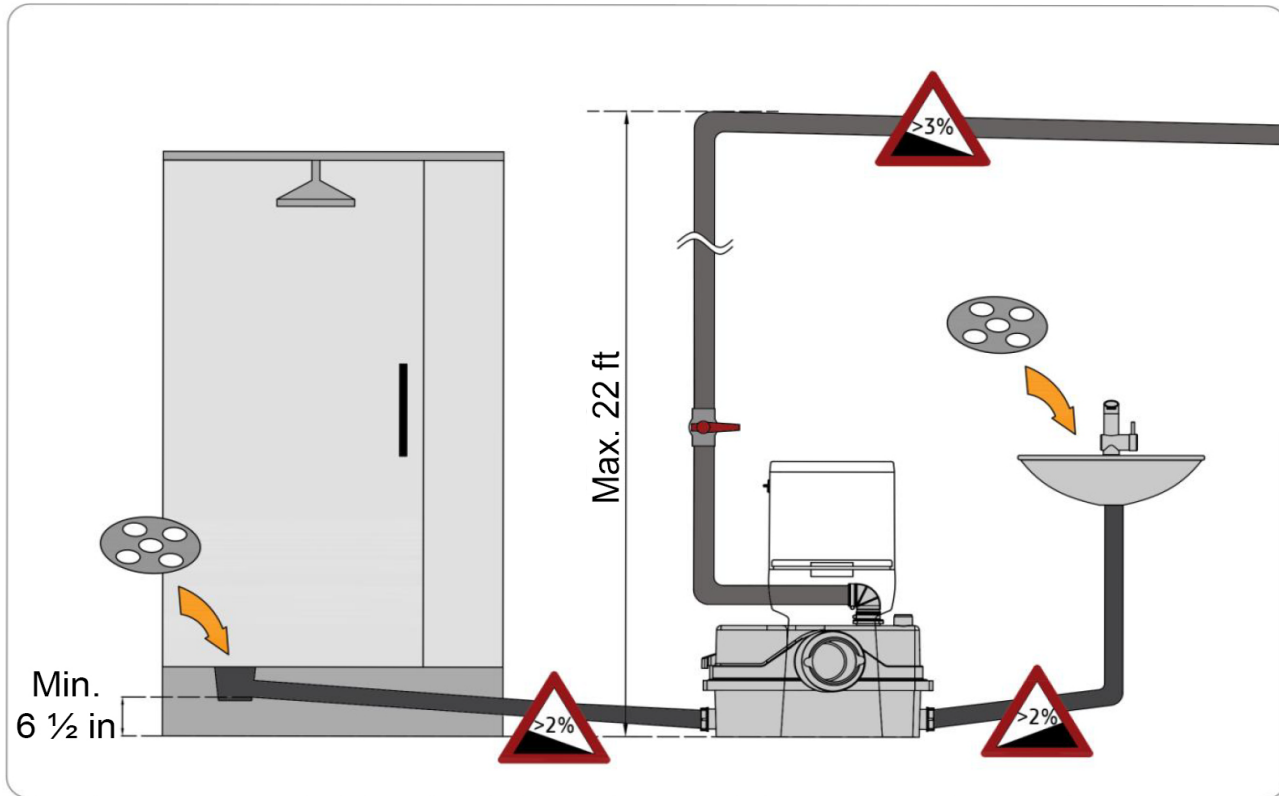
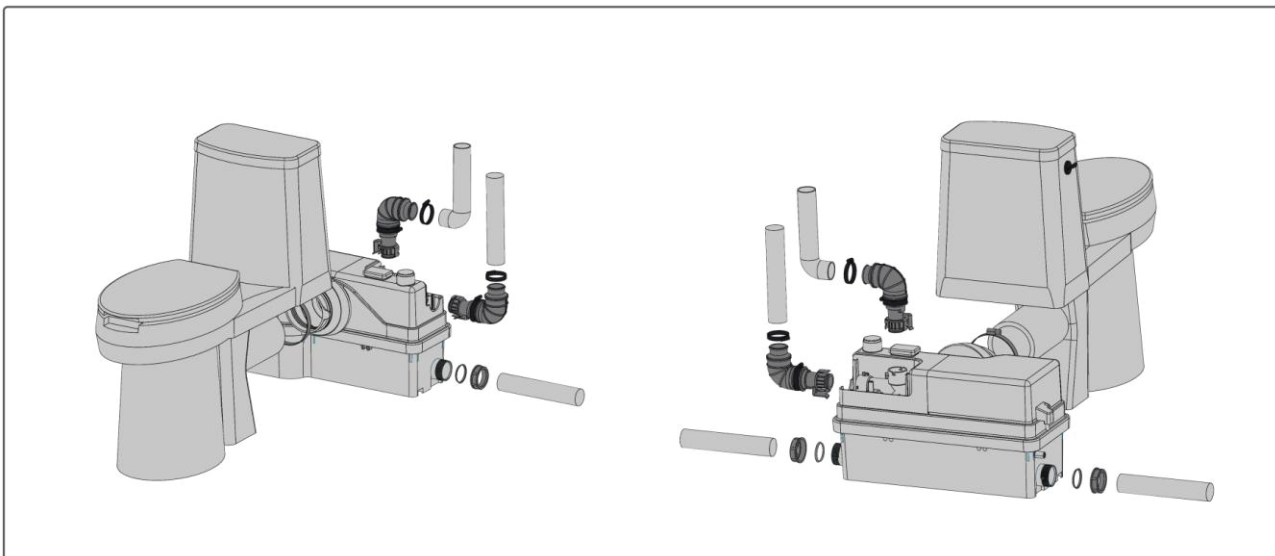
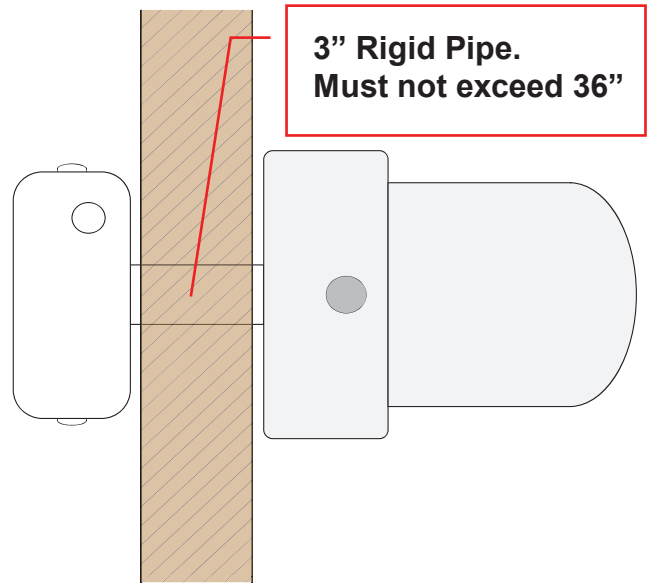

Fig.2: Connection



Option #1 Pump and Plumbing Behind Wall

For this method, you will need a 3" rigid pipe and a 3" pipe coupler (not included) to achieve proper drainage slope. Distance between toilet outlet and pump inlet cannot not exceed 36". Allow additional space for maintenance purposes.



Option #2 Exposed Pump with Plumbing In Wall

The pump is placed in front of the wall with the plumbing within the wall. Allow additional space for maintenance access purposes.

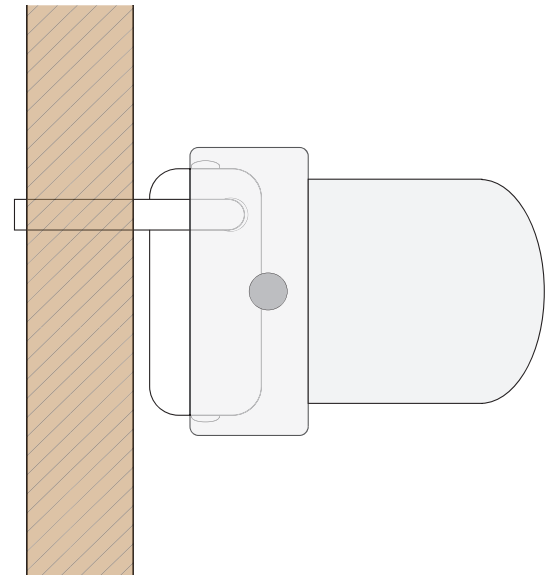

Option #3 Pump and Plumbing Exposed

Both the pump and the plumbing are in front of the wall. Allow additional space for maintenance access purposes.

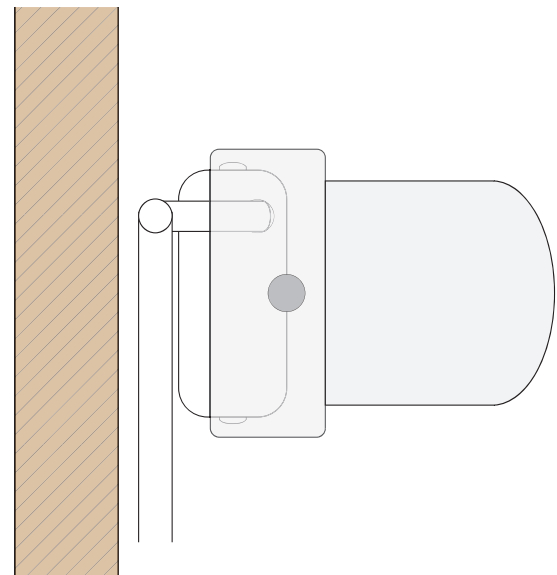

Toilet and Pump Installation

Check the following before starting installation:

Floor site should be finished and level.

Check for clearance of doors and cabinets as well as any shower enclosure.

Ensure that all plumbing and electrical fixtures do not interfere with placement of bathroom fixtures.

Rough plumbing and electrical are completed to code.

Placement of the electrical outlet must also meet local code. It is recommended to leave a 40" distance from bathtub/shower and within 6' of the pump.

Drill the floor holes for toilet placement. If installing on a concrete floor, install anchors, but **DO NOT** permanently secure fixtures until instructed.

Concrete Floor Installation:

Using Anchors:

Drill 2 holes using a 1/2" masonry drill bit; then insert the provided screws.

Wood Floor Installation:

Using Only Screws:

Drill 2 pilot holes using a 1/4" drill bit.

IMPORTANT: Do not plug the macerator into an extension cord, for this is a safety hazard and can cause injury.

Caution: To permit proper drainage it is essential to elevate the shower/tub drain to a minimum of 9" above the finished floor of the installed pump. If necessary, remember to adjust the height of the shower/tub drain upwards to allow proper grade for the plumbing connection to the pump. It is important to plan accordingly.

Toilet and Pump Installation

Part 1: Attaching Connections

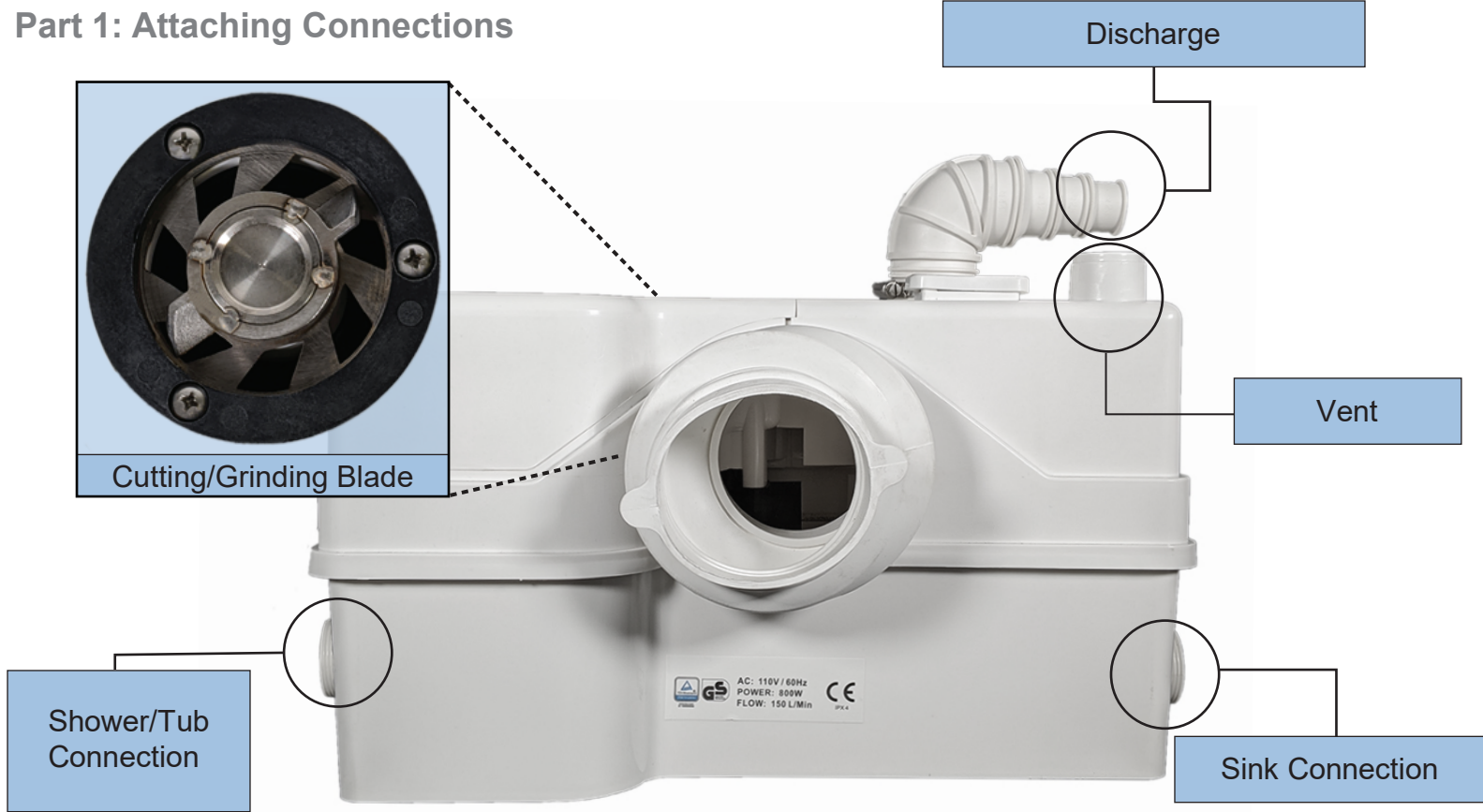

Vent Line	Shower/Tub/Sink	Discharge
<p>The macerating unit must be vented. It has 2 inlets on the top of the cover: a 1 1/2" cap and a hole of smaller diameter.</p> <p>The unit must be connected to a vent system according to the plumbing codes.</p> <p>Put the waste inlet (provided) on the cap and clamp it down.</p> <p>After, connect the vent pipe. All fixtures connected to the system must also be vented.</p>	<p>To connect to the side entries of the case, use the side connector.</p> <p>Secure with clamps.</p> <p>Plug the unused inlet with blanking plug after greasing the joint.</p> <p>Ensure when connecting a shower to the macerating unit that the underside of the shower tray is raised at least 9 inches from the floor.</p>	<p>These macerating units have an elbow and a bushing. Simply cut off the appropriate portion of the bushing in order to fit it to the discharge pipe.</p> <p>Use ridged wall pipe, not flexible pipe or hose, as flexible pipe may distort over time. Use 3/4" or 1" discharge pipe.</p> <p>Install a "full-part" ball or gate valve and a union in the discharge pipe in order to facilitate the removal of the macerating unit. Place the union or hose connector followed by the valve of the lower portion of the discharge pipe. If you need the unit to pump both vertically and horizontally, remember that 3 feet of vertical lift is equal to 30 feet of horizontal run.</p> <p>Discharge pipe work can be made from 3/4" diameter Type M Copper, CPVC, or PVC. Use long turn bends, not elbows. The connection to the soil-stack or sewer pipe must be made with an approved wye fitting. If you are not comfortable with this procedure, have a plumbing contractor install for you.</p>

Toilet and Pump Installation

Part 2: Connection to Bath/Shower/Sink

Before making any connections, make sure there is proper slope of all horizontal runs.

Bath and Shower Attachment:

1. For proper draining it is essential to elevate the shower/tub drain to a minimum of 9" above the finished floor of the installed pump. If applicable, adjust the height of the shower/tub drain upwards to allow proper grade for the plumbing connection to the pump.
2. If bathtub is connected, the 2" connection can be reduced to 1 ½" with adequate slope into the pump.
3. Measure rigid pipe from 2" pump inlet to shower/bath drain.
4. Cut pipe to fit, then connect shower/tub to 2" inlet with proper slope.

Sink Attachment:

1. Measure rigid pipe from sink drain to 1 ½" pump inlet.
2. Cut pipe to fit.

Vent to Vent Stack Attachment:

IMPORTANT: Do not use one-way air admittance valves (or cheater vents). Macerating pumps need two-way air movement. They must also be vented to the outdoors.

1. Measure rigid pipe from vent on pump to vent connection. Either to new or existing vent stack.
2. Connect rigid pipe to main vent stack of house or directly outdoors.

Discharge Line Attachment:

IMPORTANT: The pump discharge outlet has a built-in check valve. Do not install an additional check valve as this may cause the pump to malfunction.

1. Install 1 ¼" ball valve approximately 6" from pump discharge outlet.
2. Install 1 ¼" plumbing line to the home's main waste line. There must be at least 3 feet of run from the pump before connecting to the main waste line.

Toilet and Pump Installation

Part 3: Connecting Toilet and Pump

The following instructions apply for Option 1 seen on page 5.

NOTE: Make sure the floor holes are drilled before you begin the following steps.

1. Drill a hole in the wall sized to accommodate pipe slope.
2. Position clamp onto the toilet outlet. *Hint: Apply soapy water to lubricate for easier clamp application; make sure you use non-petroleum-based products only!*
3. Install the pan gasket in place making sure it covers at least 1 ½" of the toilet outlet.
4. Cut a 3" rigid pipe to fit; do not let it exceed 36".
5. Insert the pipe through the wall, connecting one end to the toilet outlet and the other to the macerator.

The pan gasket must cover at least 1 ½" of the pipe. The side cover of the macerator must also cover at least 1 ½" of the pipe.

The following instructions apply for Option 2 and 3 on page 5.

1. Position clamp onto the discharge outlet on the rear side of the toilet. If necessary, apply soapy water to lubricate the clamp for easy application.
2. Position the side cover of the macerator onto the toilet outlet and tighten, making sure it covers at least 1 ½" of the outlet.

Toilet and Pump Installation

Part 4: Toilet Assembly

NOTE: Assemble water tank as explained in the supplied instruction sheet, before proceeding with the following steps.

1. Check to make sure toilet is leveled before securing the toilet to the floor.
2. Install water tank in place. It is recommended to apply caulk around the base of the opening.
3. Secure the water tank with the provided nuts and bolts.
4. Verify that proper placement of the hose is established.
5. Install the seat cover bolts into the proper position, and secure by hand-tightening.

Part 5: Testing the System

1. Finish connecting all fittings and fixtures
2. Open the water supply valve to toilet and/or fixtures.
3. Check for leaks and correct as needed.
4. Plug the pump into wall outlet.
5. Flush toilet.
6. Double check for leaks; tighten and adjust clams and connections if necessary.

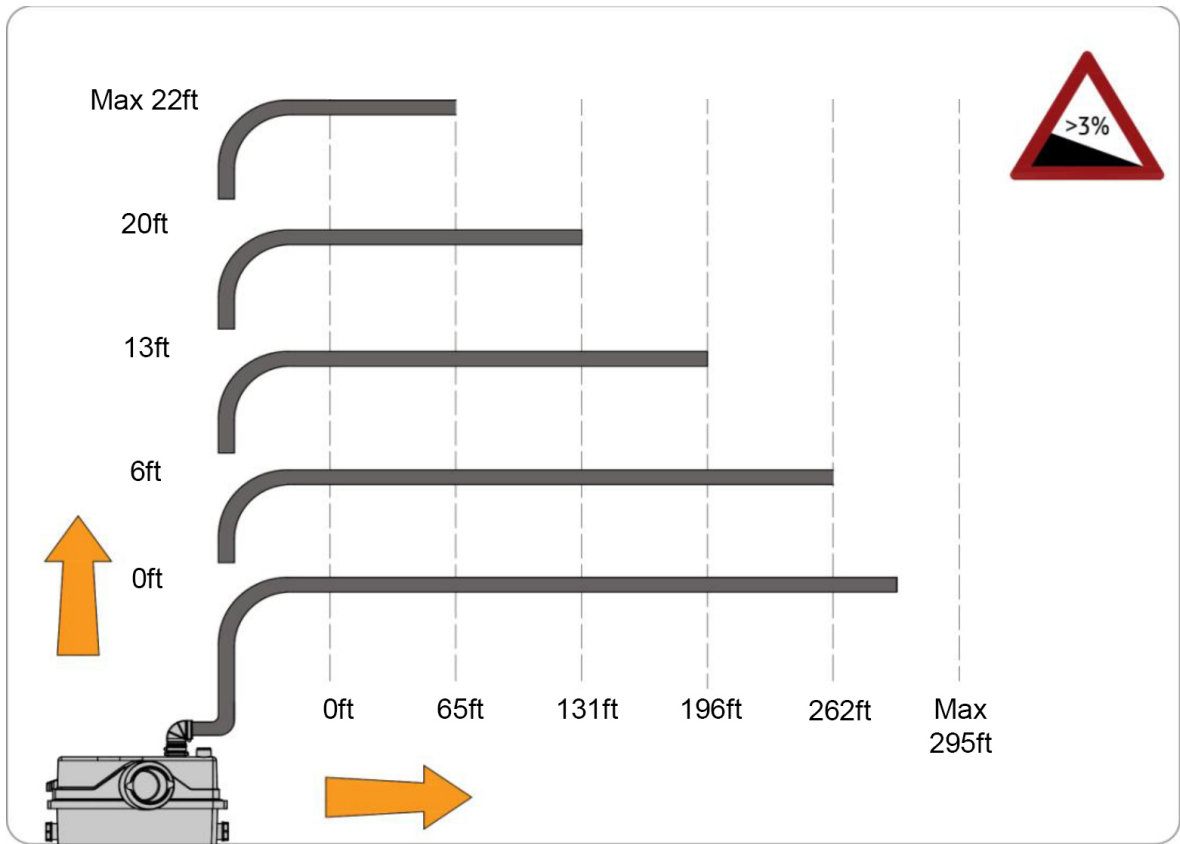
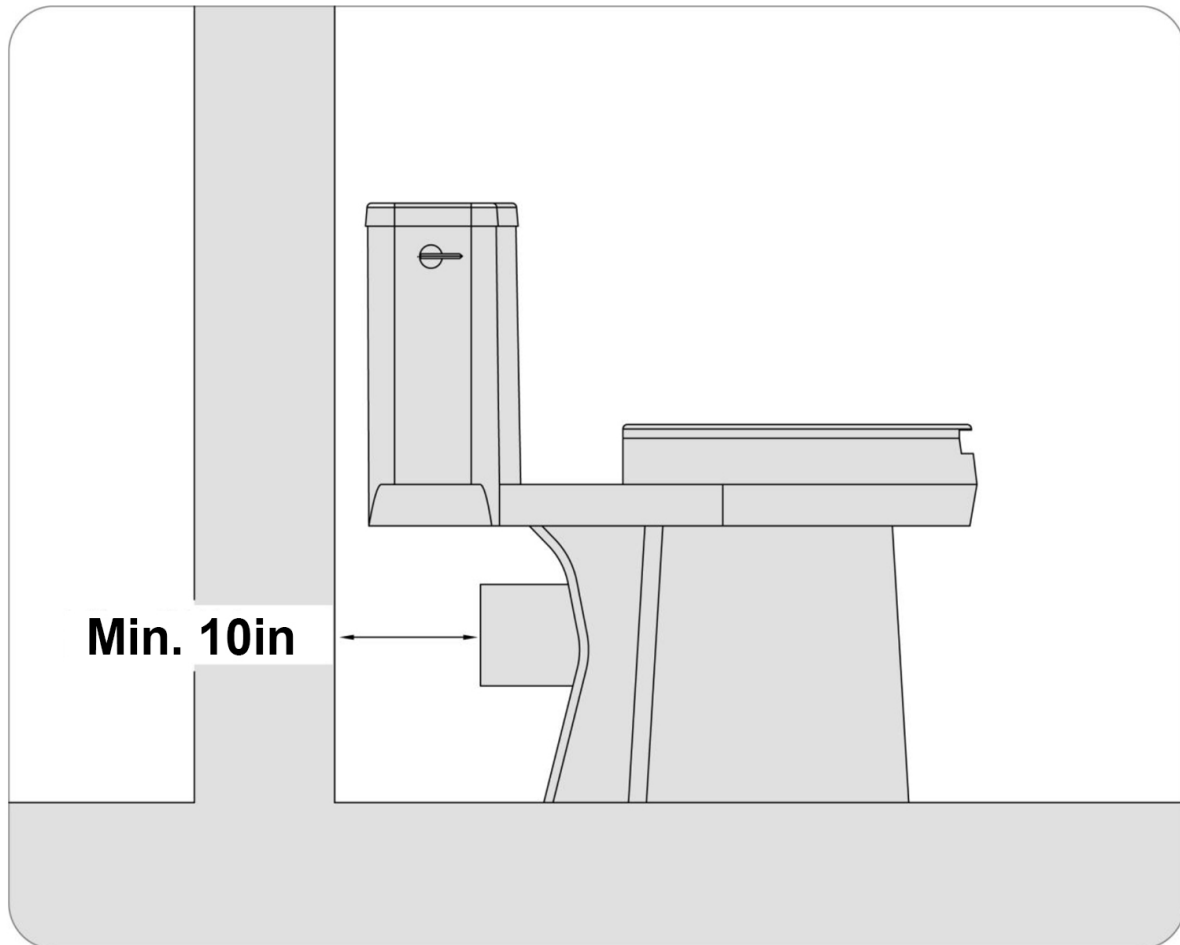

Fig.4: Distance

Min. space from toilet outlet to rear wall is 10"



We suggest to using 2pcs 45° elbow instead of 1pc 90° elbow

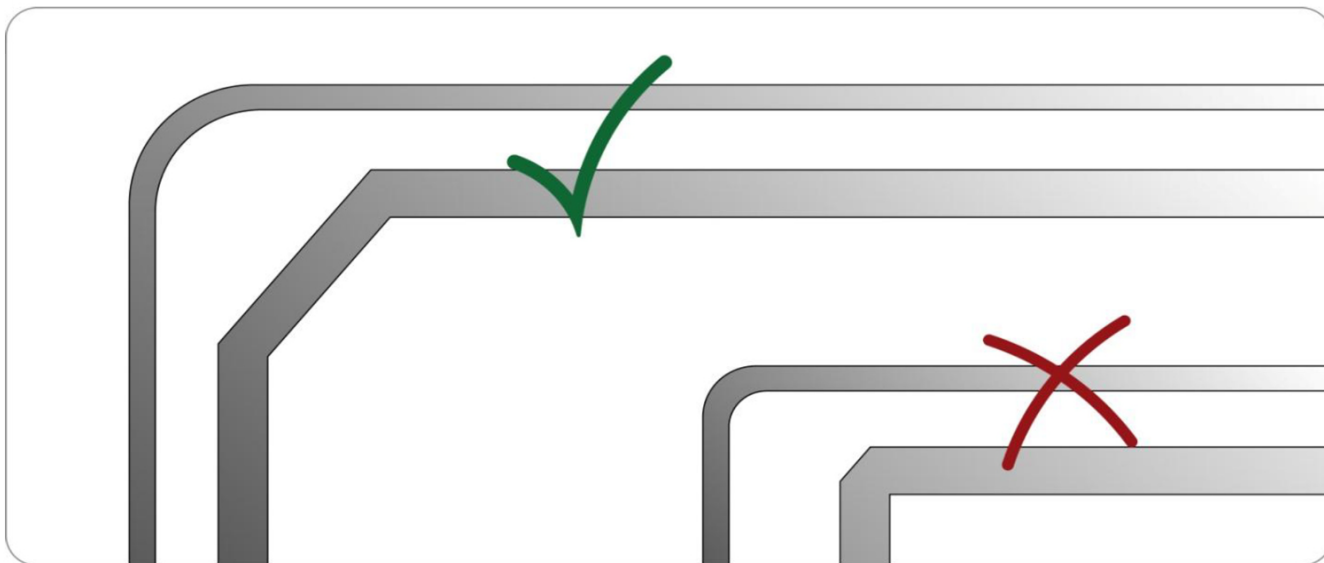
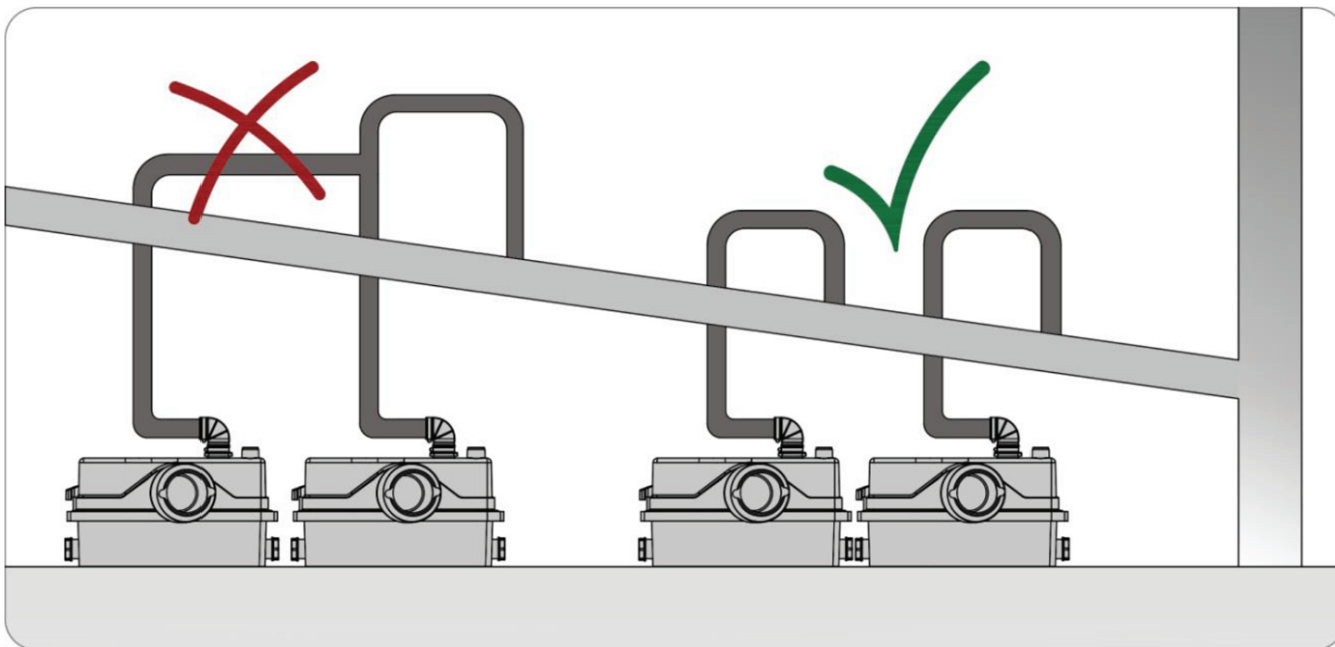
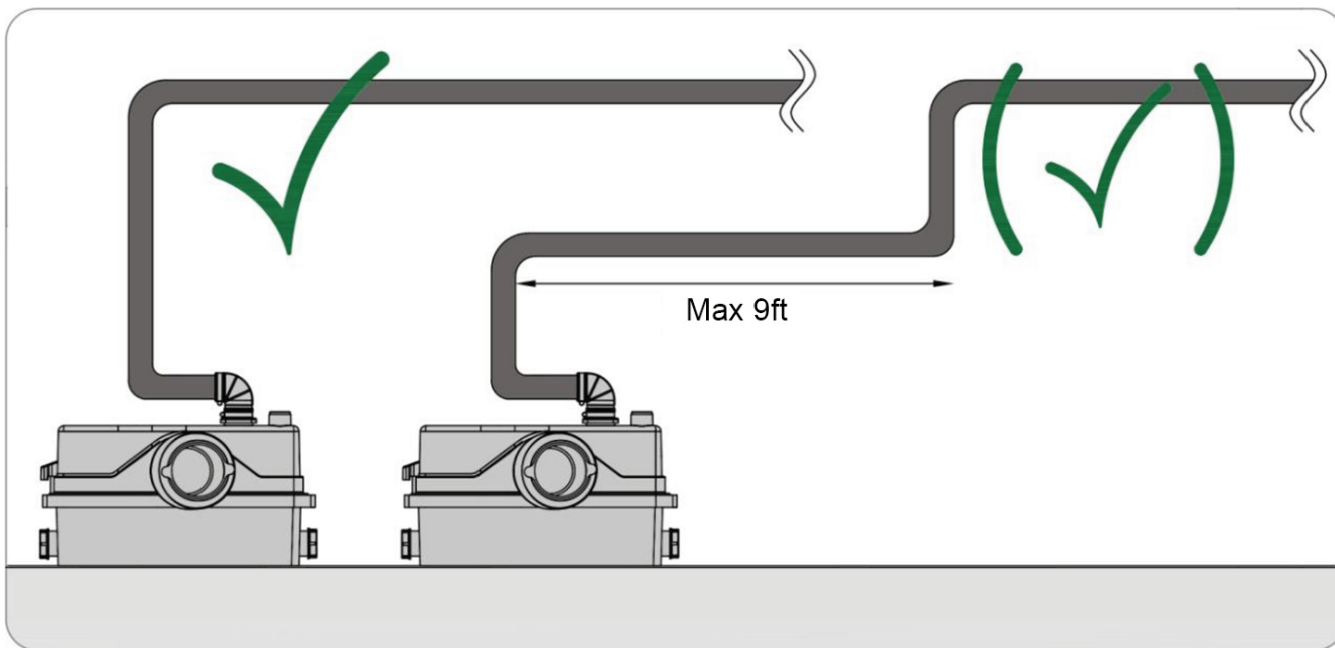

Fig.6 & 7: Discharge Pipe Connection



Warning

The use of this product requires experience with, and knowledge of the product. Persons with reduced physical, sensory, or mental capabilities must not use this product unless they are under supervision or have been instructed in the use of the product by a person responsible for their safety.

Children must not use or play with this product.

1. General Description

The HOMAC 800 are small, compact automatic lifting stations suitable for pumping domestic wastewater and sewage off places in private dwellings where wastewater cannot be led directly to the sewer by means of a natural downward slope.

Caution

If away for a long period (e.g. holidays) we recommend that you turn off the water supply to the toilet served by the unit. This is a domestic unit.

Note

Toilets connected to this unit can be used like any normal toilet, and require minimum maintenance. The unit will operate automatically as soon as the required level of water enters the tank.

Caution

Only the disposal of toilet paper, faecal matter and waste water will be covered by warranty. Any damage due to foreign bodies such as cotton, condoms, sanitary towels, wet wipes, food, hair, metal, wood or plastic objects, will not be covered by warranty. Solvents, acids and other chemicals can also cause damage to the unit, and will invalidate the warranty.

2. Applications

The product is only suitable for pumping wastewater from a cabinet shower, bidet, and/or washbasin as well as sewage from a toilet.

Note

- Not for public and heavy commercial or industrial use, only limited number of users. Installation with direct connection to toilet and in the same room as sanitary appliances.
- A second toilet must be available above the backflow level.
- The product must be fastened to the floor to prevent uplift and turning.

3. Pumped Liquids

Domestic wastewater and sewage containing toilet paper and faeces. Ordinary liquids for cleaning of the appliances connected. pH value: 4-10.

Caution

The product must not pump harsh chemicals or solvents. See the quick guide. The product is designed for flush volumes of 4, 6 and 9 litres. A 4-litre flush is permissible only if the amount of solids in the pumped liquid is small.

4. Installation

Caution

- Do not pull or lift the product by the supply cable.
- The product must be accessible for maintenance and repair.
- The product must be placed in a frost-free room to prevent the pumped liquid from freezing. Make sure that all external pipework is adequately insulated.

Note

- The discharge pipe must be made of rigid material, such as copper, or of rigid PVC with solvent-welded joints.
- To prevent the transmission of vibrations to buildings, make sure that the pipework is thoroughly fixed and that fittings cannot move and are not in contact with building parts.
- An alarm device for acoustic alarm in case of malfunction or high level in the tank is available as an accessory (noise level 75 dB(A)).
- Extension pipes between the toilet and lifting station must not be longer than 5 ½" due to the increased risk of clogging.

5. Electrical Connection

Make sure that the product is suitable for the supply voltage and frequency available at the installation site. The electrical connection must be carried out in accordance with local regulations.

Warning

- The product must be earthed.
- The installation must include an earth leakage circuit breaker for protection against earth fault currents. This ensures protection when using a Schuko plug or another plug with earth pin.
- The product must be connected to a main switch with a minimum contact gap of 3 mm in all poles. In case of over heating, a thermal switch cuts out the motor and cuts it in automatically when it has cooled sufficiently.

6. Service

Warning

- The product must only be serviced by trained service personnel.
- If the supply cable is damaged, it must be replaced by the manufacturer, the manufacturer's service partner, or a similarly qualified person.
- To ensure safe and reliable operation, always use original spare parts from the manufacturer.
- The product must be thoroughly cleaned before it is returned for service, otherwise the warranty will be void.

6.1 Maintenance

The lifting station does not require any special maintenance, but we recommend that you check operation and pipe connections at least once a year. Change the carbon filter once a year. See section 6.2 Service instructions.

6.2 Service Instructions

Thanks to the product design, service is easy in case of malfunction or blocked pump. Digits in the following sections refer to the pictures in the appendix at the end of this booklet.

Warning

Before carrying out any service work, remove the fuse, pull out the plug, or switch off the power supply. Make sure that the power supply cannot be accidentally switched on. All rotating parts must have stopped moving. The product must only be serviced by a trained service personnel.

Note

Make sure that the little tube in the top of the pipe did not become blocked when you cleaned the pipe!

Caution

Lubricate the sealing area of the pressure switch for easier fitting.

Foreign Body in Tank

If the water level in the tank is above the motor flange, drain the tank by means of the drain hose (accessory).

Note

Lift the unit vertically before tilting it!

Warning

Beware of the sharp edges on the grinder. Wear protective gloves.

7. Fault Finding

Warning

Remove the fuse, pull out the plug, or switch off the power supply. Make sure that the power supply cannot be accidentally switched on. All rotating parts must have stopped moving. The product must only be serviced by trained service personnel.

Fault	Cause	Solution
1. Motor does not start when the level in the tank reaches the start level.	a) Supply failure	Reestablish the power supply.
	b) Fuse blown. If new fuse blows at once, either cable or motor is faulty	Replace the fuse. Measure cable & motor. If cable or motor is defective, replace the defective parts.
	c) Impeller/grinder stuck. Thermal switch tripped.	Free the impeller/grinder, & wait until the motor is cooled down & the thermal switch has reset.
	d) Pressure switch pipe blocked.	Remove the pressure switch & clean the pipe.
2. Motor hums but does not operate.	a) Impeller/grinder stuck.	Free the impeller/grinder & check that it can rotate freely.
	b) Motor or capacitor defective.	Replace the motor or capacitor.
	c) Control board defective.	Replace the control board.
3. Motor runs continuously or at irregular intervals.	a) Water leaking from inlet into tank.	Check for leaking appliances.
	b) Water leaking back into tank from discharge pipe.	Check the non-return flap.
	c) Pressure switch defective.	Replace the pressure switch unit.
4. Motor runs but does not evacuate water.	a) Pump or tank blocked.	Remove blockage.
	b) Air lock in pump or vent hole in pump housing blocked.	Check operation of vent valve in the tank. Check that the carbon filter is not wet. Check that the vent hole in the pump housing is not blocked.
	c) Discharge port or pipe is blocked.	Remove blockage. Check the non-return flap.
5. The lifting station evacuates slowly.	a) Discharge pipe is too long or has an excessive number of bends.	Increase discharge pipe size. Alter pipework to reduce number of bends. Change bends to soft bends.
	b) The pump housing is leaky.	Replace the pump housing (service part).
	c) Hydraulics or grinder blocked	Check and clean the hydraulics & grinder.
6. Rattling noise from the lifting station, but water is evacuated.	a) Foreign body hitting the impeller/grinder.	Remove the foreign body.
7. Odor from the tank.	a) Carbon filter contaminated	Replace the carbon filter.
8. Water from shower or another appliance connected to the lower inlets drains off slowly. Backflow from the lifting station.	a) Non-return flap in inlet stuck, does not open or does not close sufficiently.	Check the non-return flap.
	b) Hydraulics or grinder blocked.	Check and clean the hydraulics & grinder.
	c) The start level has changed.	Check and clean the pressure switch pipe.
	d) Inlet pipe diameter is too small.	Use a pipe with a larger diameter.

8. Maintenance

 **DISCONNECT THE ELECTRICAL POWER SUPPLY, BEFORE ATTEMPTING ANY WORK ON THE UNIT.**

No need of any particular maintenance.

This unit is fitted with an active carbon filter, and requires no external venting.



Correct disposal of this product

This marking shown on the product or its literature, indicates that it should not be disposed with other household wastes at the end of its working life. To prevent possible harm to the environment or human health from uncontrolled waste disposal, please separate this from other types of wastes and recycle it responsibly to promote the sustainable reuse of material resources.

Household users should contact either the retailer where they purchased this product, or their local government office, for details of where and how they can take this item for environmentally safe recycling.

Business users should contact their supplier and check the terms and conditions of the purchase contract. This product should not be mixed with other commercial wastes for disposal

System Operation

What to Expect

This toilet operates on a different principle than a typical siphon toilet, resulting in a different sound and flush action. When activated, the pump pulses a few times.

Cleaning

Use only non-abrasive, non-petroleum products to clean the pump.

Prime the Pump

If pump initially runs for more than 10 seconds, prime the pump as follows:

- a. Unplug cord from wall outlet.
- b. Wait 15 seconds. Plug cord back into wall outlet.
- c. Flush again. If pump runs more than 10 seconds, repeats steps a-c

Winterization

If the Lift Assure system is exposed to freezing temperatures, please make sure that all fixtures, inlets, and discharge lines are winterized using non-toxic propylene glycol (RV Marine AntiFreeze). Use sufficient quantity of antifreeze to ensure all pipes are protected.

First, you must shut off the water supply. Flush toilet to empty the tank. Pour RV/Marine Antifreeze into toilet and all fixtures. Press manual switch to run antifreeze through system.

Clearing Debris from Pump

While the Lift Assure does not need any maintenance under normal conditions, it is okay to clean out the macerating unit once a year. Do not use bleach. The macerating unit starts automatically once the toilet is flushed or the other bathroom appliance discharge and ceases operation once the contents have finished pumping.

ATTENTION: Do not return any merchandise to the vendor.

For customer service, returns, or technical questions, please call Lift Assure's technical support at (1-877-862-7049) or (1-727-233-0490)

LIMITED WARRANTY

One Year From Date of Purchase

As per terms and conditions below, Lift Assure, (herein referred to as the Company) warrants that it will repair or replace the product or any of its component parts, at the Company's discretion if it deems that the product or part is defective or fails to meet the rated performance due to a manufacturing or material default.

If replacement is to be issued, this will only be extended to the first month (30 days) starting from the date of purchase. Warranty repairs will apply after such date up to the warranty conclusion.

Terms and Conditions

- The product must be installed in accordance to the manual or manuals.
- The product must not have been subject to accident, negligence, misuse, improper installation or repair, or exposure to harmful products or substances.
- The alleged defect or fault must be reported to the Company during the established warranty period.
- The warranty is for one year from purchase date.
- The warranty is for **parts only**. The warranty covers the cost of repair or replacement of defective parts. It also covers the cost of freight (ground service) shipping of replacement parts that are covered under this warranty to you.

Part and Product Exchange

- The customer must have an "authorized return number" from the manufacturer in order to validate exchange.
- Lift Assure reserves the right to decline repair at their discretion. Warranty does not cover the cost of the exchange or total replacement of the unit.
- The customer must provide proof of purchase to warrant a repair or an exchange. The warranty is void if the identification number or date of manufacture stamp have been tampered with or deemed illegible in any way.

Limitations

1. In no event shall the Company be liable for any special, incidental, or consequential damage, loss, or injury of any kind, arising from, or in connection with the product or any component thereof.
2. The guarantee is transferable only when the product remains at the same premises as its initial installation.

For questions and further explanation, be sure to contact Lift Assure support staff at the phone number provided.

IMPORTANT

When claiming a warranty repair, you will need the information you have written down below.
Please ensure that you have all particulars when requesting work.

Owner Name:	
Order/Purchase Number:	
Installation Address:	
Purchased From:	
Installed by:	
Date of Purchase:	
Serial Number:	
Date of Manufacture: (see manufacture's tag on unit)	