

[Other Installation Manuals](#)

CONFER PLASTICS, INC.

CONFER PLASTICS, INC. POOL ENTRY SYSTEM FOR ABOVE-GROUND POOLS

Adjusts to fit most above-ground pools with flat or slightly dished bottoms

<u>PARTS LIST</u>				<u>HARDWARE PACK</u>		
<u>Code#</u>	<u>Qty</u>	<u>Description</u>	<u>CTN#</u>	<u>Qty</u>	<u>Description</u>	<u>CTN#</u>
1	2	Side Panel	2	3	1/4 - 20 Hex Nut	1
2	5	Step	1	3	1/4 - 20 X 1œ Screw	1
3	4	Riser	1	3	#10 x 1-1/4œ Self Tapping Screw	1
4	1	Kickplate	1	2	Large Plug/Side Panels	1
5	1	Deck Connector	1	1	Label for Top Riser	1
6	2	Base	1	2	Threaded Cap	1
7	2	Anti-Entrapment Panel	2	2	Red Plug	1
8	4	Threaded Height Adjuster	2	1	Instructions	1
				1	Registration Card	1

Tools Required For Assembly

- Mallet or Hammer
- Phillips Screwdriver
- Cordless Drill Motor
- 1/8œ Drill Bit
- Level
- Hacksaw
- Knife
- Small Block of Wood
- Tape Measure

Step 1.

1. Measure the Depth of Your Pool.

A) For Deck Level Pool Entry (one (1) unit attached to a deck), measure from the top of the deck to the bottom of the pool approximately eight (8) inches out from the pool wall (Measurement #1). Take a second measurement approximately three (3) feet out from the pool wall (Measurement #2).

B) For Ground Level Pool Entry (two (2) units attached to each other), take the measurements from the top of the pool top seat. Add one-half (1/2) inch to these measurements for clearance.

*Whether you use method "A" or "B", write your measurements for future reference.

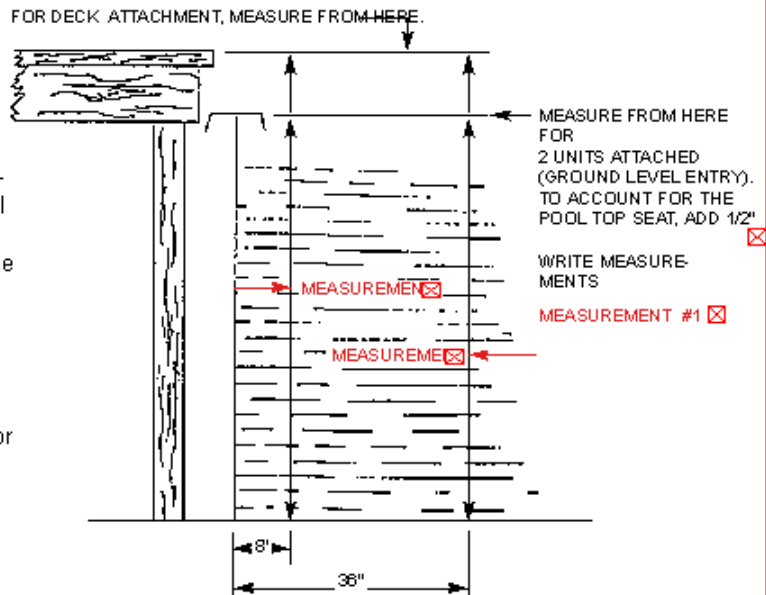

Step 2.

Remove the wedges from every step using a utility knife. Do not discard.

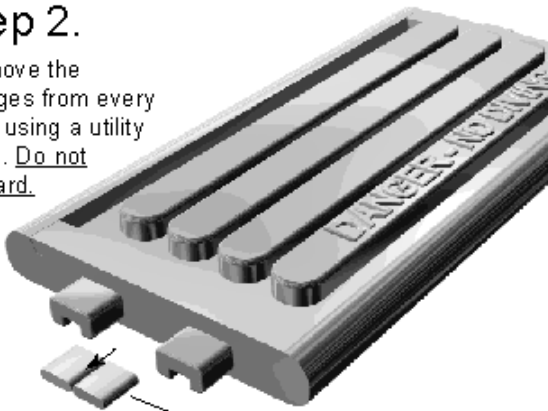

Remove Wedges and SAVE. They will be needed in step 7

Step 3.

The risers slip into grooves on steps.

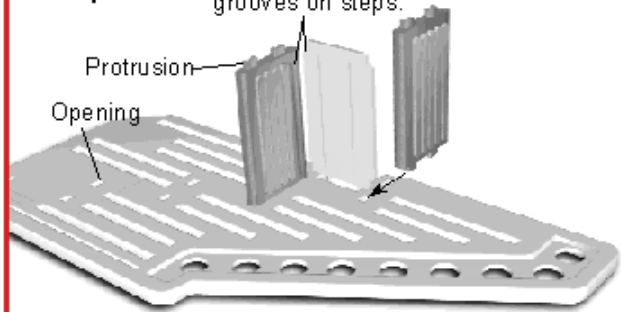

Lay the side panel on a clean flat surface. Firmly push the protrusion of the steps into the opening of the handrail section. Insert the risers into the grooves on the steps as shown above.

Step 4.

Affix the warning label to center of top riser.

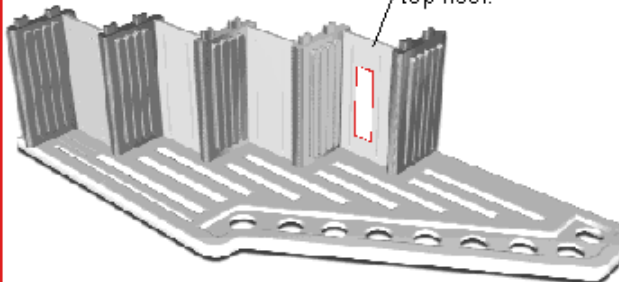

Continue adding steps and risers until all are firmly in position.
Note: position risers so center hole faces "back" of steps.

Step 5.

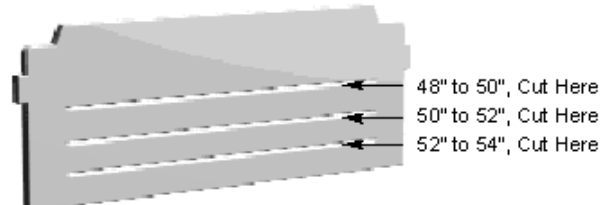

After determining the correct height from measurement #2 in step 1, cut the kickplate to the appropriate height. Use a hacksaw to cut the ends (next to the pre-scored line) and a knife to separate the kickplate at the pre-scored line. Place the kickplate in position below the bottom step.

Step 6. Push down firmly

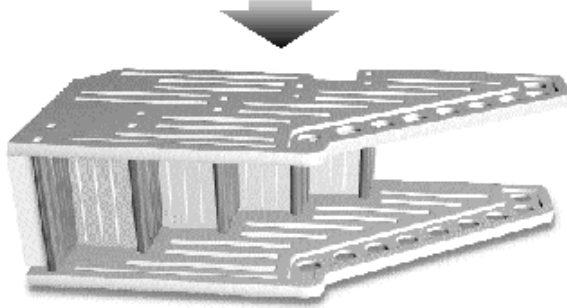

Push the second side panel firmly down on the step protrusions. It may be necessary to tap the side panel using a hammer and block of wood until seated correctly.

Step 7.

Secure each step by tapping a locking wedge (saved from Step 2) between the side panel and the top surface of the step protrusions.

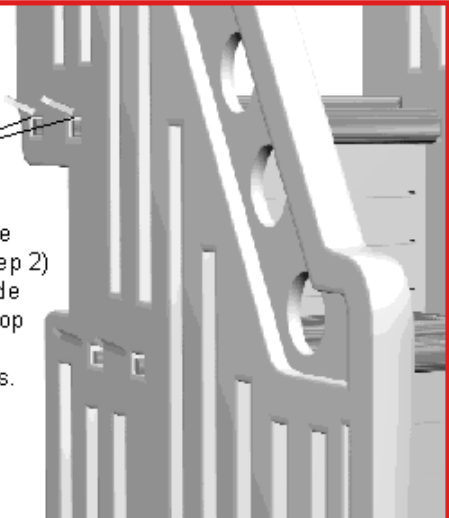

Step 8.

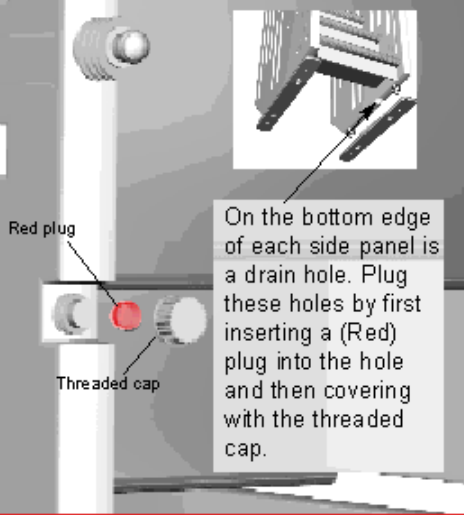

On the bottom edge of each side panel is a drain hole. Plug these holes by first inserting a (Red) plug into the hole and then covering with the threaded cap.

Step 9.

To attach the base, position the unit as shown.

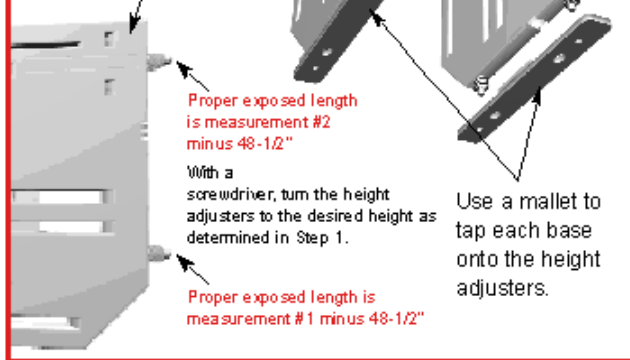

Proper exposed length is measurement #2 minus 48-1/2"

With a screwdriver, turn the height adjusters to the desired height as determined in Step 1.

Proper exposed length is measurement #1 minus 48-1/2"

Use a mallet to tap each base onto the height adjusters.

Step 10.

If you are fastening the pool entry system to a deck: Attach the deck connector to the top step using the three (3) 1/4-20x1" screws and hex nuts (nuts are installed on underside of deck connector).

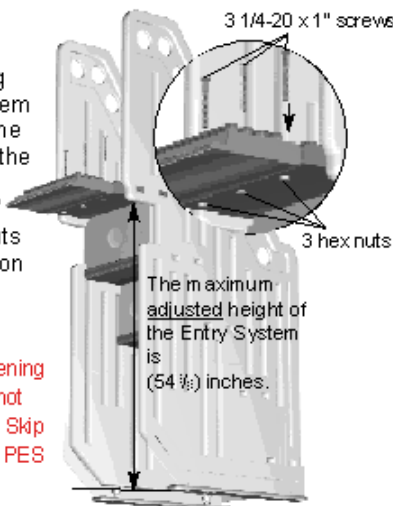

The maximum adjusted height of the Entry System is (54 1/2) inches.

NOTE: If you are fastening two units together, do not attach deck connector. Skip to Page 5 "Joining two PES Pool Entry Systems".

Step 11.

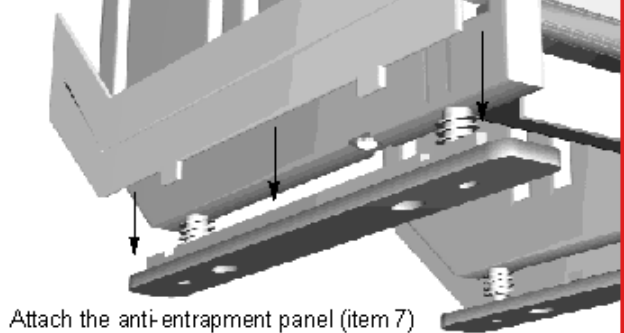

Attach the anti-entrapment panel (item 7) to both sides of the unit as shown. Position and push firmly down into base until it locks securely into place.

Note: Anti-Entrapment panels are not needed if the unit is left at 48".

Step 12. Note: Two people are required for this operation

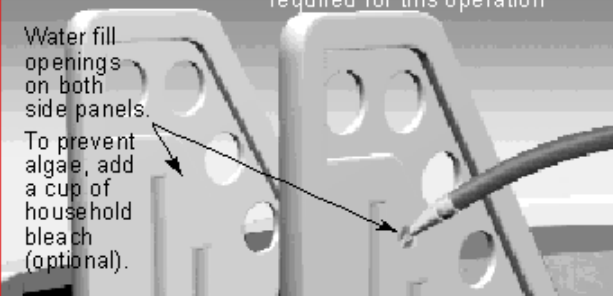

Water fill openings on both side panels. To prevent algae, add a cup of household bleach (optional).

Carefully submerge the unit into the pool. Add water to the side panels through the water fill openings located near the top of each side panel. When completely filled, press the supplied (white) plugs into the openings on both side panels.

Step 13.



Tilt the unit to allow the steps to fill with water. When bubbling ceases, steps are filled. Steps must be filled completely to prevent floating.

Step 14.



Attach with 3 #10 x 1-1/4" Self Tapping Screws

Position the PES with attached deck connector and drill three pilot holes. Attach to deck using 3 #10 x 1-1/4" Self Tapping Screws. Keep 2" clearance between unit and pool wall.

Safety Information

- 1) Always follow the manufacturer's recommendations for the safe use of all hand tools and equipment.
- 2) Always use a cordless drill.
- 3) Do not use the Pool Entry System for any purpose other than that for which it is intended.
- 4) When lifting awkward or heavy loads, have another person help you.
- 5) Maximum weight on steps not to exceed **400 lbs.**

Warning: Exceeding the recommended weight requirement may cause the unit to fail.

Replacement Parts

Thank you for purchasing a C.P.I. product. Although we make exceptional effort to ensure the quality of our products, occasionally an error or omission may occur. If you discover that a part of this product is missing or defective, please contact us for a replacement.

In The U.S.A. Call: (800) 635-3213
or (716) 693-2056
Or Write To:
Confer Plastics, Inc. 97 Wtmer Road,
North Tonawanda, NY 14120 U.S.A.
www.conferladders.com

Joining two Pool Entry Systems.



When joining two units together, the deck connectors will not be used. Assemble both units and position the in-pool unit in the desired location, after filling it in the same manner as step #12. Allow approximately two (2) inches of clearance between the side of the pool (pool liner) and the Entry System. Make any necessary height adjustments to ensure that all four (4) threaded adjusters are supporting the unit, that the unit is level and does not wobble, and that the underside of the top step is about (1/2) inch above the pool top seat. The outside unit should rest on cement patio blocks. Position and level the outside unit so that both units can be joined using the six (6) 1/4-20 x 1" machine screws and hex nuts. The hex nuts should be on the outside of the fastening flange of the side panels (See diagram on pg 2). Press the large plugs into the fill opening of the outside unit. It is not necessary to fill the out

Optional mounting method when deck height is greater than (54-1/2) inches.

Adjust the height of the entry system so that the top step, at minimum, reaches the face board of the deck, however, the height of the bottom surface of the top step must not exceed (54-1/2) inches. Cut a piece of 2 x 4 pressure treated lumber (28-1/4" long) and place it edge down on the top step between the two flanges of the side panels. Secure in place with four #10 x 1-1/4" screws (not provided) through the two lower holes in each of the mounting flanges of the side panel. After securing the 2 x 4 to the unit, position the unit so that the 2 x 4 meets the face board of the deck. It can then be secured in place using wood lag screws. Three 2-1/2" long lag screws are required (Lag screws not provided).

Removal and storage of Pool Entry System:

In cold climates the Entry System must be removed from the pool and drained to prevent freezing and cracking. To remove the unit disconnect it from the deck (or the outside unit), pull large plugs and tip it so that some of the water drains from the large fill openings. Once the unit is lighter it will become buoyant so that it can be turned onto its side and the bottom drain caps and plugs can be removed. With the unit on its side, slowly pull the Entry System from the water allowing the water to drain out of the unit. Once the unit is out of the pool be sure that all the water drains out. If desired the unit can be disassembled for winter storage. Use a flat blade screwdriver to remove the locking wedges and carefully pull the side panels away from the steps. (Be sure to save all caps and locking wedges for reassembly).

SAFETY RULES

- Always follow the manufacturer's recommendations for the safe use of all hand tools and equipment.
- Do not use the Confer-Step for any purpose other than that for which it is intended.
- When lifting awkward or heavy loads, have another person help you.
- Maximum weight on steps not to exceed 400 lbs.

*Warning: Exceeding the recommended weight requirement may cause the unit to fail.

*DANGER: Never use an electric drill in or around the pool

LIMITED, PRO-RATED WARRANTY

Confer Plastics, Inc. warrants their swimming pool ladders to be free from defects in workmanship for one year from date of purchase. After the first year the cost to replace a part is as follows:

2nd Year - 20%	*of current parts list price
3rd Year - 40%	
4th Year - 60%	
5th Year - 80%	

Plus shipping/handling charges

DO NOT RETURN DEFECTIVE PART TO DEALER

The defective part should be returned, postpaid, to:

Confer Plastics, Inc.

Witmer and River Roads

P.O. Box 217

North Tonawanda, N.Y. 14120

Enclose proof-of-purchase (receipts, etc.) showing date purchased, your name, address, and daytime phone number. You will be notified of cost to replace part.

This warranty gives you specific legal rights, and you may also have other rights which may vary from state to state.